

# Push chain 040 I

## 3 Push chain with pitch 40 mm

### 3.1 Type 40 PS

#### 3.1.1 Technical data

- max. push force (for 1 meter of chain unguided, load guided): .....8000 N
- weight per meter:..... 4,8 kg
- number of links per meter: ..... 25

#### 3.1.2 Dimensions

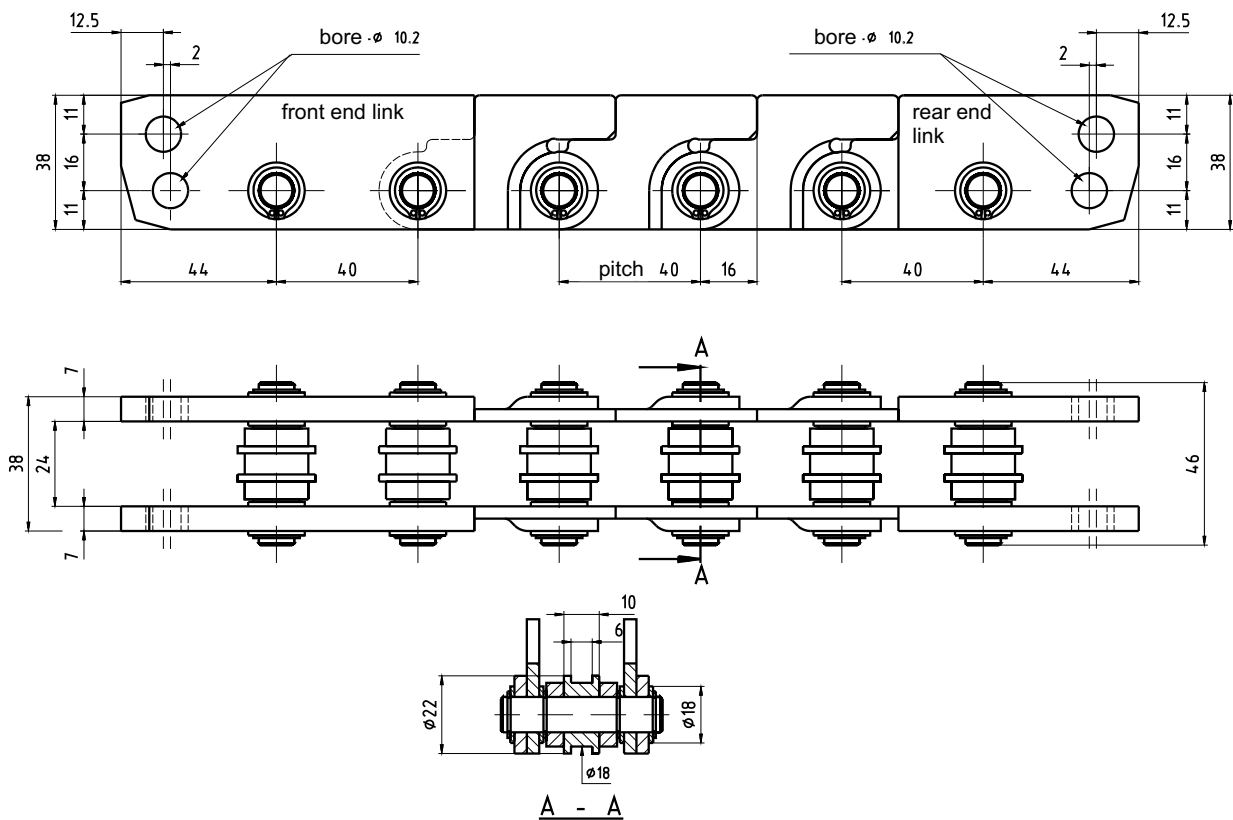

# Push chain 040 I

## Type 40 PS

### 3.1.3 Assembly of the standard chain link 5-0401-100.00

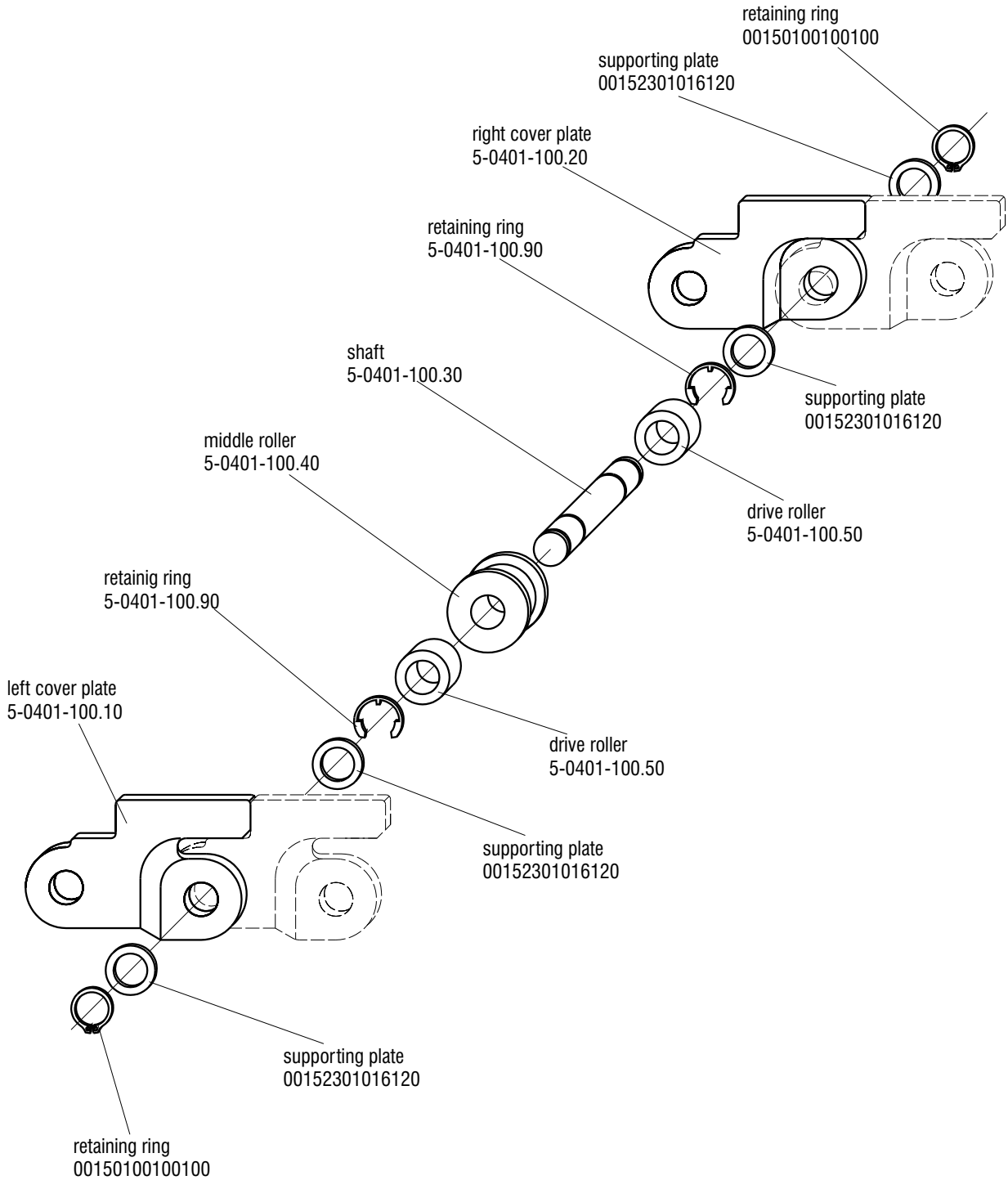

Subject to technical changes